

OEM System Modules

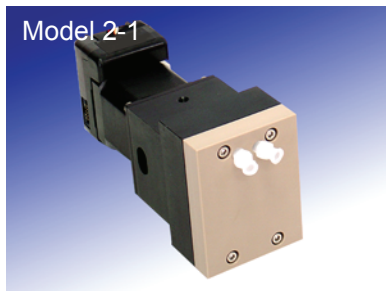

Model 2-1

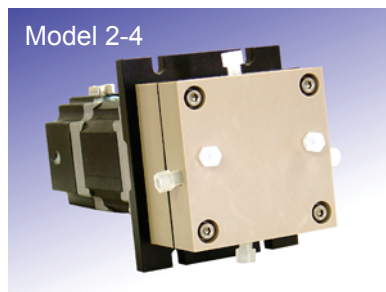
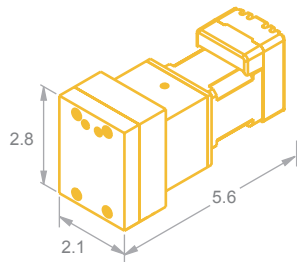

Model 2-4

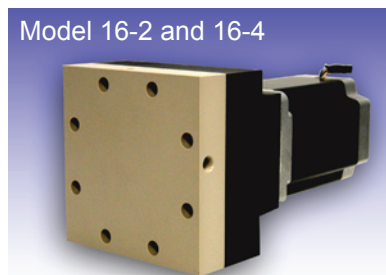
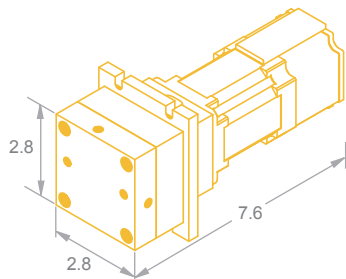

Model 16-2 and 16-4

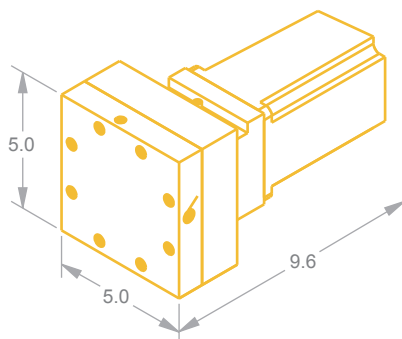

All dimensions are approximate and shown in inches

2- series

Model 2-1

Low-cost metering up to 50 mL/min. Single-cylinder design; pulsation depends on control method.

Model 2-4

Dispensing and low-pulsation metering up to 200 mL/min. Four-cylinder design for continuous flow.

16- series

Model 16-2

Dispensing and metering up to 640 mL/min. Two-cylinder design; pulsation depends on control method.

Model 16-4

Dispensing and low-pulsation metering up to 1280 mL/min. Four-cylinder design for continuous flow.

16-series systems are recommended for applications with higher-viscosity liquids.

Materials

The wetted parts of "Standard configuration" Encynova System Modules are made from chemically-resistant materials, creating a versatile, durable fluid control system. For applications that involve more aggressive fluids, an even more robust "Inert" wetted parts option is available. Other options may be available- please contact us about your 'problem liquid.'

Wetted Parts Materials

		Standard	Inert
Housing	2-series	Delrin™	PEEK™
	16-series	Ertalyte® or Aluminum	Ertalyte® or Aluminum
Manifold		PEEK™, Tefzel™, 316L stainless steel	PEEK™, Tefzel™, 316L stainless steel
Manifold O-rings		Viton™	Perfluoroelastomer
Port Plates		Ceramic Al2O3	Ceramic Al2O3
Pistons		Teflon™ or UHMW	Teflon™ or UHMW
Cylinder/ fluid chamber		Borosilicate glass (Pyrex™)	Borosilicate glass (Pyrex™)
Connecting Rods		Delrin™	PEEK™

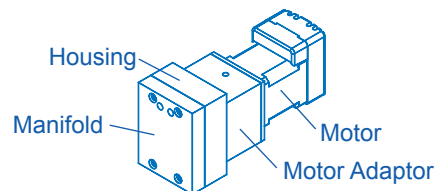
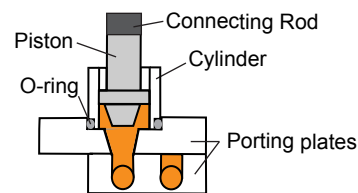

Hazardous or rated environment enclosures may be constructed to meet your needs. For hydrocarbon liquid applications using diesel, gasoline (or similar), special pistons and o-rings are available.

OEM System Module Specifications *

Nova System Modules	Model 2 - 4	Model 16 - 4		
Metering				
Metering Range	200 nL/min - 200 mL/min	1600 nL/min - 1280 mL/min		
Metering Accuracy	< 0.5 %Cv	< 0.5 %Cv		
NovaFlow™ Metering				
Range	200 nL/min - 20 mL/min	1600 nL/min - 200 mL/min		
Accuracy	< 1 %Cv	< 1 %Cv		
Pulsation*** (%Cv of total flow at mid range rate)	3 %Cv	3 %Cv		
NovaSpense™ Dispensing				
NovaSpense™ Dispensing Accuracy	0.1 %Cv	0.1 %Cv		
NovaSpense™ Dispensing Precision	0.05 %Cv	0.05 %Cv		
Motor: Servo, with features for increased dispensing accuracy and near-pulseless metering.				
Basic System Modules	Model 2 - 1	Model 2 - 4	Model 16 - 2	Model 16 - 4
Metering**				
Range w/ stepper motor: integrated motor/driver	0.2 - 50 mL/min	.08 - 200 mL/min		
Range w/ stepper motor: Two-phase 1.8 degree	0.2 - 50 mL/min	6 - 200 mL/min	25 - 640 mL/min	50 - 1280 mL/min
Accuracy	< 2 %Cv	< 2 %Cv	< 2 %Cv	< 2 %Cv
Dispensing				
Accuracy**	1-20 %Cv	1-20 %Cv	1-20 %Cv	1-20 %Cv
Repeatability	< 1 %Cv	< 1 %Cv	< 1 %Cv	< 1 %Cv
General specs for all systems	Model 2 - 1	Model 2 - 4	Model 16 - 2	Model 16 - 4
Number of cylinders	1	4	2	4
Displacement volume				
per cylinder (ml/rev)	0.2	0.2	1.6	1.6
total (ml/rev)	0.2	0.8	3.2	6.4
Pressure max. operating	125psi (8bar)	125psi (8bar)	125psi (8bar)	125psi (8bar)
Manifold Fitting Size	¼"-28 UNF	¼"-28 UNF	1/8" NPT	1/8" NPT
	(custom sizes are available)	1/16" NPT	¼" NPT	¼" NPT
Approx. Dimensions l x w x h (inches)	5.6 x 2.2 x 2.8	7.6 x 2.8 x 2.8	9.6 x 5.0 x 5.0	9.6 x 5.0 x 5.0
Weight (varys depending on motor type)	1.6lb (0.7kg)	3.8lb (1.7kg)	8.6lb (3.9kg)	11.1lb (5.0kg)

Dispensing specs are based on tests with 1.0 mL of RO water at room temperature and 1 atm of pressure.

* Please consult Encynova for information specific to your application.

** Specifications are dependent on control system used.

*** For flow rates of less than 1 mL/min the calculated instantaneous pulsation levels increase.

Observed pulsation levels depend greatly on fluidic setup and measurement technique.

Cv: The **coefficient of variation**, expressed in percent, is used to describe the standard deviation (s) relative to the mean (\bar{X}).
 $Cv = [(100) (s) / \bar{X}]$

Nova System Communications

To harness precision, you must have control. That's why our Nova Systems have a flexible communications platform. RS-485 communication capability allows you to easily control the Nova Systems with our predefined commands. Use a PC, PLC, or any other source that can generate 8-bit ASCII commands to precisely control as many Nova Systems as you need.

LabVIEW™, C++ and Visual Basic compatibility provide the versatility required for simple and effective integration into your process. Connect the Nova System, assign it to an address on your network, and you are ready to go. Up to 250 Modules can be controlled on one RS-485 network using ASCII serial strings. Digital I/O and analog capability are standard in Nova Systems and in Basic Systems that use the integrated motor/driver.

Move it. Control it. Measure it.

Encynova systems are different from basic pumps because they do more than typical pumps. Measurement and flow control capabilities are incorporated into the pump's design. No external valves or flow meters are needed. Shown at right: Four Model 2-1 System Modules panel-mounted in a standard 19-inch rack.

